



# Flat Track 100

## Sliding & Folding Door Systems



### Product Overview

The Flat Track 100 sliding hardware with its various finishes and hanger styles is just as at home in a trendy café or loft apartment as it is in a barn conversion, cottage or renovation on a listed building.

For doors up to 100kg with nylon bearing wheels offering smooth silent operation across the flat bar, the Flat Track 100 system offers aesthetic appeal and versatility including new soft closing and bi-passing bracket options without compromising on performance.

### Features

- Durable steel hangers with PA66 nylon wheels run effortlessly and silently across a solid flat track
- Nylon wheels supplied with precision sealed ball bearings
- Anti-jump blocks prevent door from being removed from track
- Soft closing available, concealed behind the flat bar track
- Easy to install
- Choice of hanger styles and finishes available
- For internal use only

### Technical Specifications

- Maximum Door Weight: 100kg
- Minimum Door Width: 550mm
- Door Thickness: 35mm - 44mm

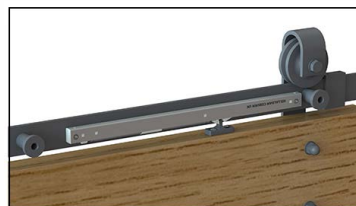

Soft Closer  
(Fitted behind track)



Hanger



Track stop and anti-jump block



Guide



**Straight Hanger**



**Available Finishes**



Black



Rust



Brushed 304 SS

**Arrowhead Hanger**



**Available Finishes**



Black



Rust

**Wagon Wheel Hanger**



**Available Finishes**



Black

**Top Mount Hanger**



**Available Finishes**



Black



Brushed 304 SS

**Flat track 100**

Maximum door weight 100kg

DH - Door height

DWi - Door width, minimum 550mm

DT - Door thickness, between 35mm and 44mm

OW - Opening width

OH - Opening height

Side view

Side view  
With Bi-passing Bracket

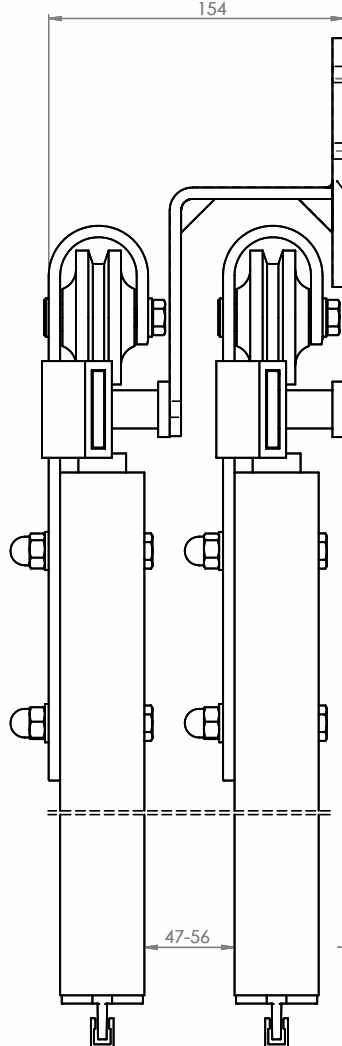
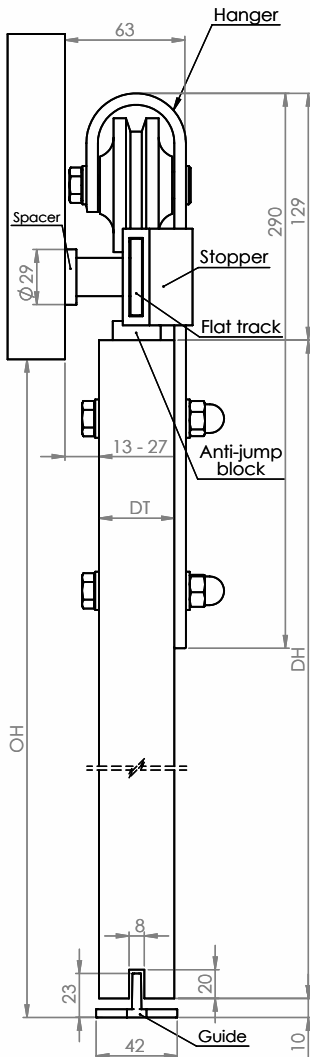

**NOTE:**  
For doors over 1500mm wide but under 100kg a second track must be used with a jointing bracket  
\* If using jointing brackets, track stops in the centre of the track cannot be used unless hanger placement on the door is adjusted accordingly.

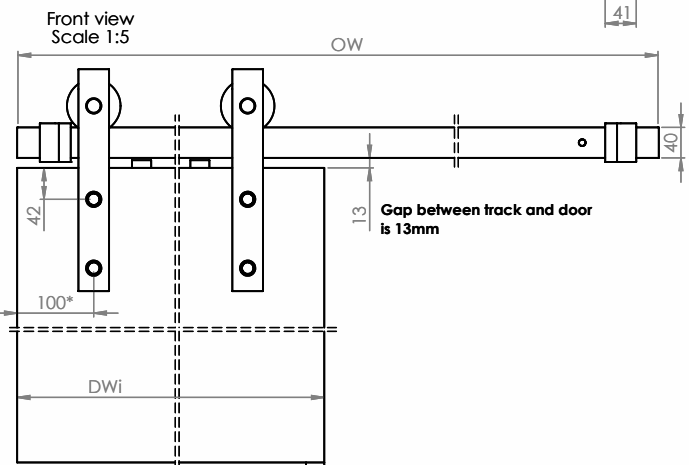
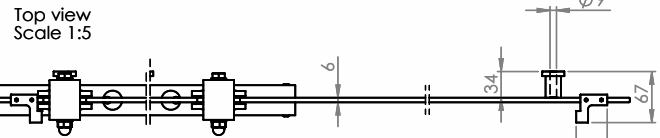
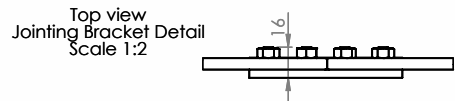
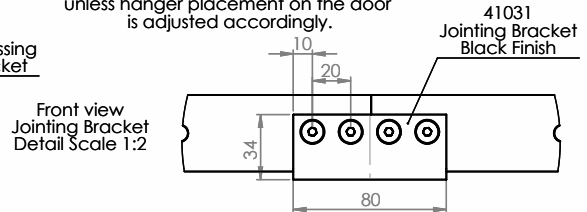

**For further information on our products and services:**

Tel: +44 (0)20 8545 6680 sales@coburn.co.uk www.coburn.co.uk

**Coburn Sliding Systems Limited**

Unit 1, Cardinal West, Cardinal Way, Cardinal Distribution Park.  
Godmanchester, Huntingdon, Cambridgeshire, PE29 2XN United Kingdom.

