

INSTALLATION INSTRUCTIONS

UNLESS OTHERWISE STATED, ALL DIMENSIONS ARE IN MILLIMETRES

DOUBLE 60X

MAXIMUM WEIGHT OF DOOR 27kg (60lb)
MAXIMUM DOOR HEIGHT 2m (6ft 6ins)
MAXIMUM DOOR WIDTH 1m (3ft 3ft)
DOOR THICKNESS 36mm - 44mm



COMPONENTS:

- 27-2 ALUMINIUM TRACK
- 23-261 HANGERS
- 22-391 GUIDES
- 97-728 DOOR STOP
- No.6 x 20(3/4") WOODSCREWS FOR TRACK
- No.6 x 16 (5/8") WOODSCREWS FOR HANGERS AND OTHERS

TRACK HOLE PITCH CENTRES

Cut track to length.

Drill two $\varnothing 4\text{mm}$ holes, 25mm and 35mm at each side of both ends of the track.

Drill two similar holes 210mm and 200mm at one end of the track in line with the first two holes.

Forming two rows, drill other holes approximately 200mm apart along the track.

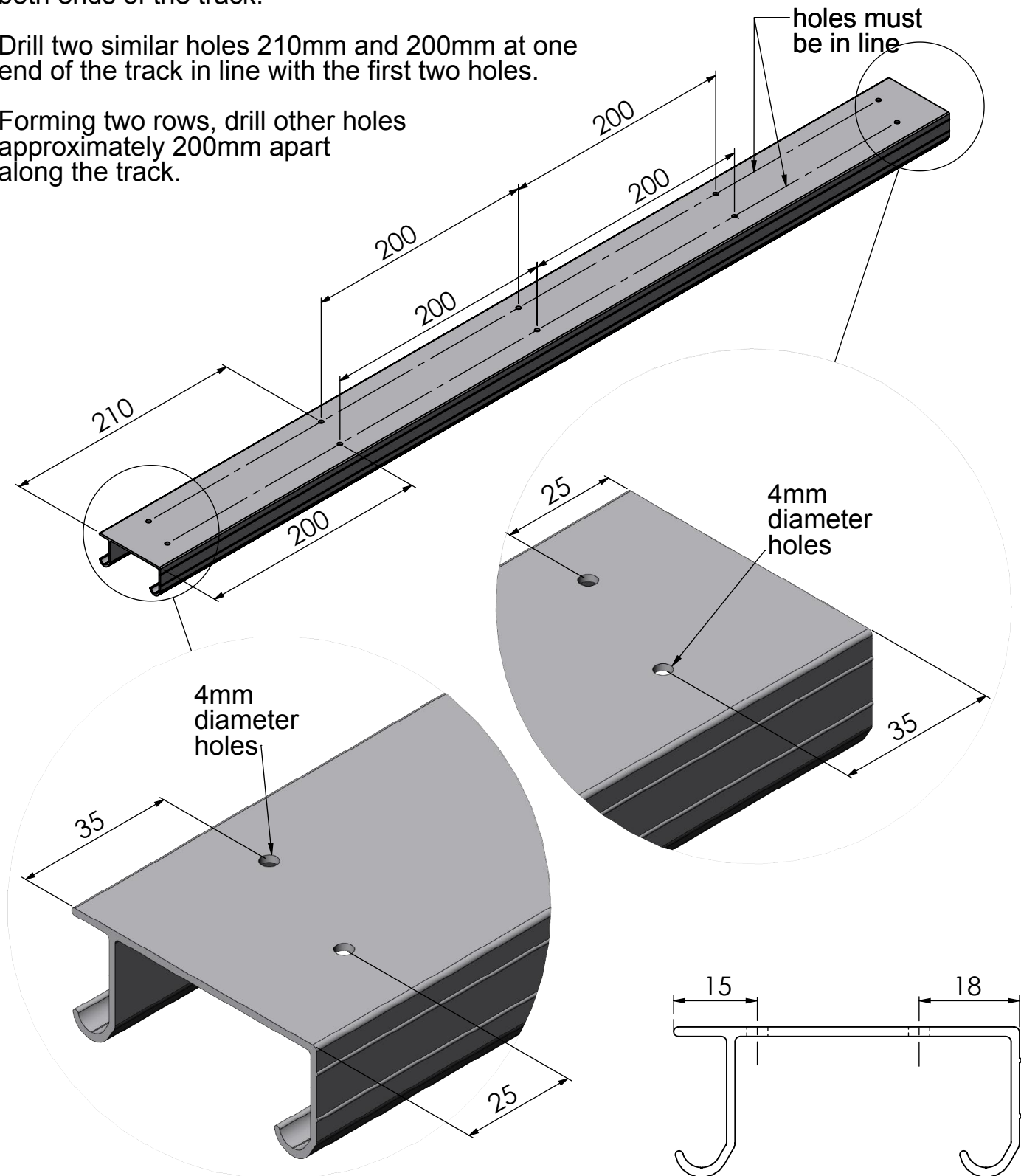

The number of holes will depend on the length of the track.

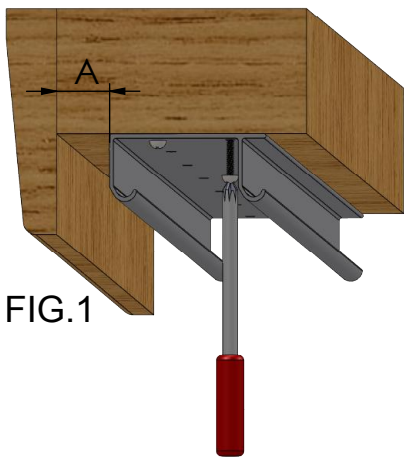

FIG.1

Cut track to required length and fix with No.6 x 20(3/4") woodscrews to soffit/support allowing gaps (Dim. 'A') as shown in fig. 1

Secure hangers to inside top edge of doors close to each side and top of door in line with points of curved sides. Use No.6 x 16 (5/8") woodscrews positioned at top of two slots, omitting centre screws at this stage. See fig.2

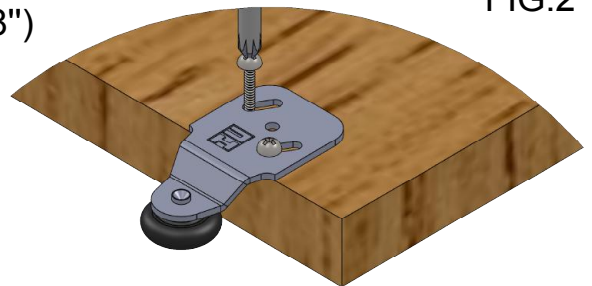

FIG.2

FIG.3



Holding the door at an angle hook the inside door onto the track . See fig.3. Avoid the use of force as hangers may be damaged and the smooth running action impaired.

Hook the outer doors onto the track/tracks in the same way avoiding the use of force See fig.4

DOOR THICKNESS (mm)	DIM. A (mm)
44	29
42	27
40	25
38	23
36	21



FIG.4

FIG.5

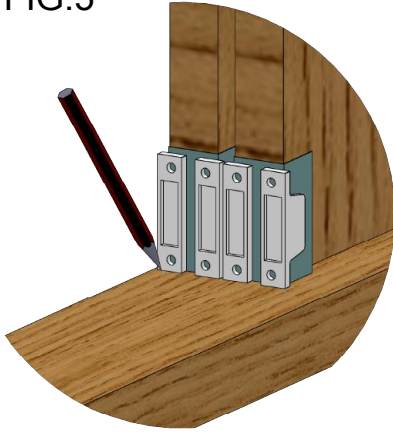

To obtain clearance for guiding, wrap thin cardboard (0.5 - 1.0mm thick) around the edge of each door in turn and mark position of guides when door hangs plumb. See fig.5

FIG.6

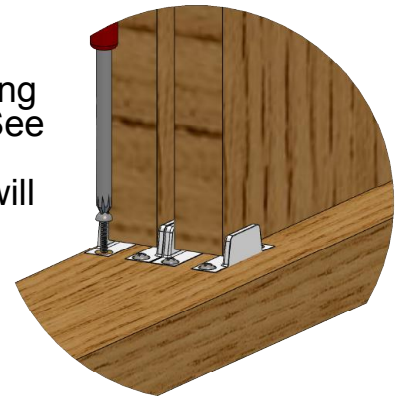

Screw guides down centrally in opening using No.6 x 16 (5/8") woodscrews. See fig.6.
If guides are to be let in flush, doors will have to be removed first.

FIG.7

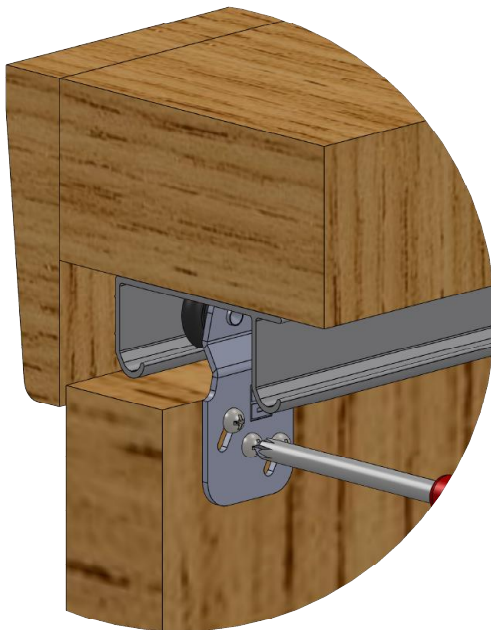

Slightly loosen the two screws in each hanger and adjust doors until they hang plumb and close squarely against the frame. Screw in centre screw to prevent further movement. See fig.7

FIG.8

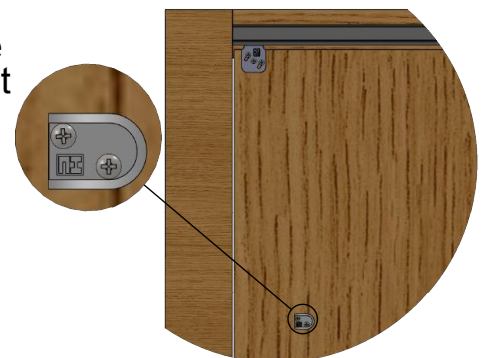

Screw door stop to inside of front door at mid-height with No.6 x 16(5/8") woodscrews. See fig.8.

Flush pulls are fitted outside at two-thirds high.

Wipe inside of tracks with an oily rag from time to time to aid free movement.

TWO DOOR SETUP

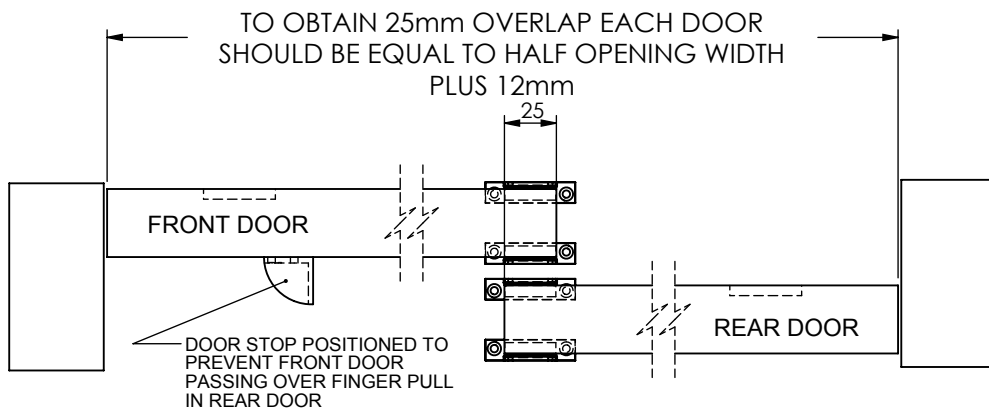

THREE DOOR SETUP

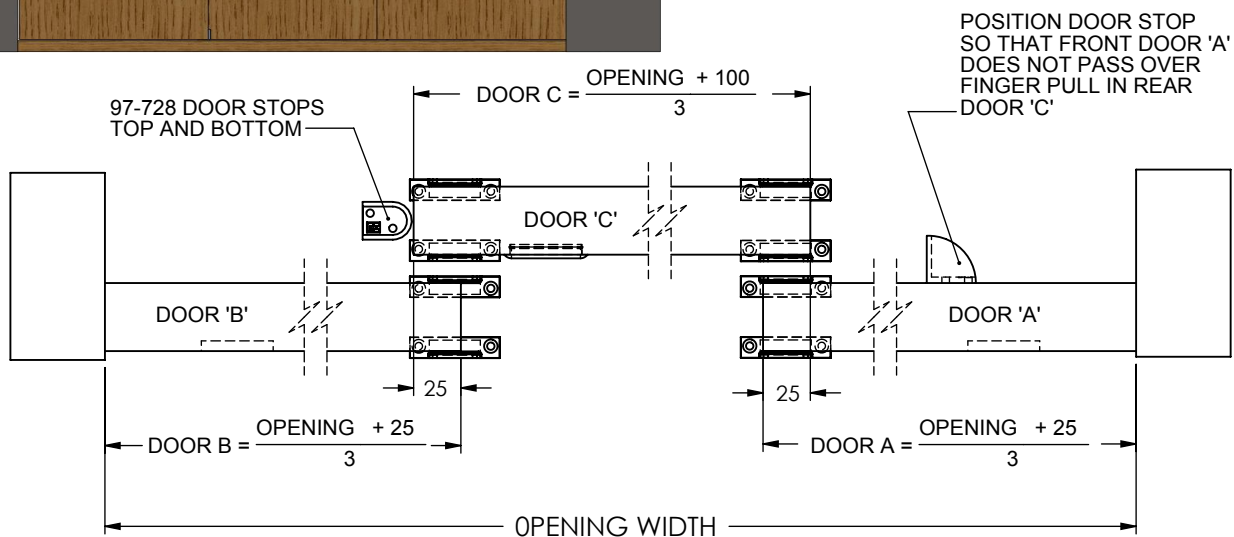

SECTION VIEW OF THE DOUBLE 60X SETUP

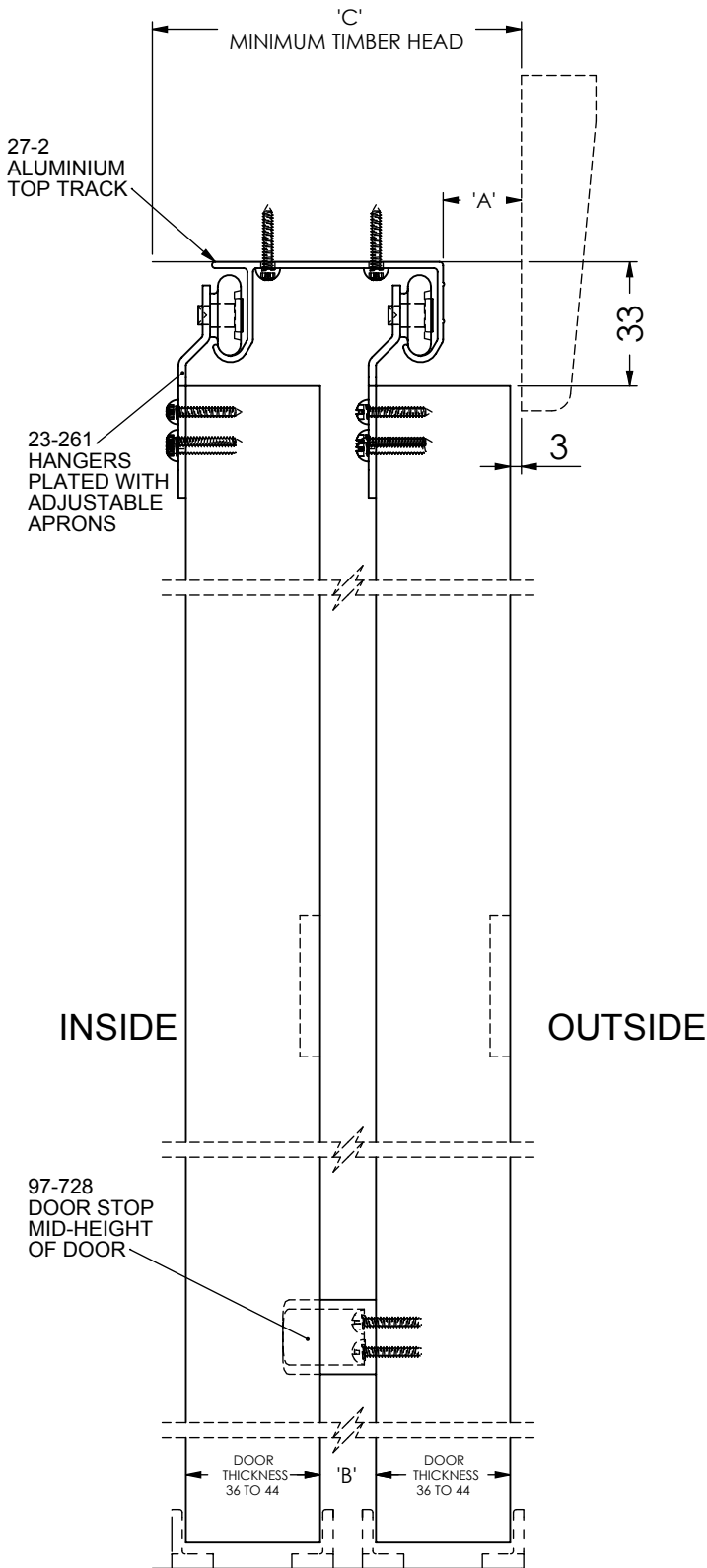

DOOR THICKNESS (mm)	DIM. A (mm)	DIM. B (mm)	DIM. C (mm)
44	29	7	107
42	27	9	105
40	25	11	103
38	23	13	101
36	21	15	99

BOTTOM GUIDE SETUP

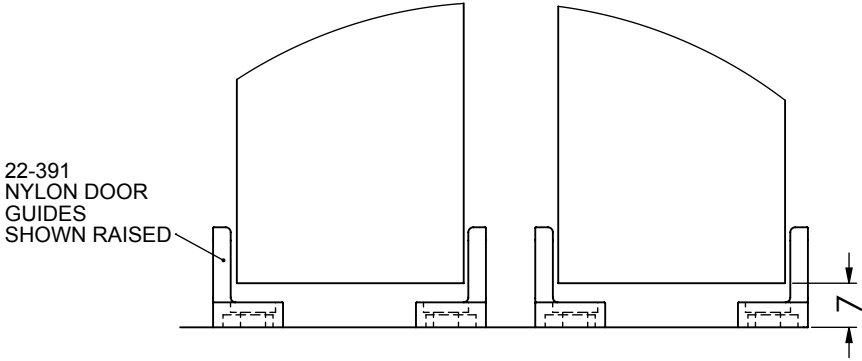

GUIDE SURFACE FIXED

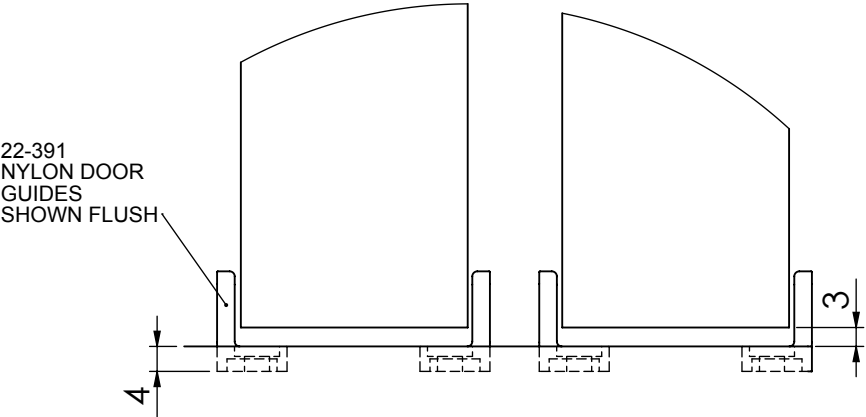

GUIDE REBATED INTO THE FLOOR

DOUBLE 60X



Coburn Sliding Systems Ltd
Unit 1, Cardinal West, Cardinal Way,
Godmanchester, PE29 2XN, United Kingdom

Phone: +44 (0)20 8545 6680

Fax: +44 (0)20 8545 6720

E-mail: sales@coburn.co.uk

www.coburn.co.uk