



Kirk Sandall Industrial Estate, Doncaster, South  
Yorkshire, DN3 1QR

+44 (0)1302 310 113  
enquiries@prosolveproducts.com  
www. prosolveproducts.com

ProSolve is trademark of S.T.L Trading Company  
Limited  
Reg in England No: 5230722  
VAT Reg No: 381 3533 58

## DATASHEET

### ProSolve Twinslot (white)

ProSolve Codes:

Uprights: DU170BC, DU430BC, DU710BC, DU1000BC, DU1220BC,  
DU1600BC, DU1980BC, DU2400BC

Brackets: SDB120BC, SDB170BC, SDB220BC, SDB270BC, SDB320BC,  
SDB370BC, SDB420BC, SDB470BC, SDB570BC, SDB610BC



The ProSolve Twinslot 'Shelf-Lok' system combines adjustability with strength and versatility. The system comprises a wall fixed twinslot steel upright to take a range of steel 'U' brackets for supporting various types of shelves. Medium and heavy-duty brackets are also available for supporting heavier loads. The components are fabricated from 1.5mm thick steel and finished in Dupont Alesta AM™ anti—microbial powder coating. White, brown, black, chrome, silver and stainless steel finishes are available.

### ProSolve Twinslot Terminology

**Twinslot** – wall mounted shelving that are fitted vertically, they have a series of twin slots and fixing holes in the front that allow for the 'uprights' to be attached to the wall then accept a range of accessories for the purpose of display or storage.

**Shelf-Lok** – a unique locking system that allows the bracket to become automatically locked into the upright when installed correctly, this locking system stops the bracket from been accidentally knocked out of the twinslots.

**Upright pitch** – the distance between the top of one twinslot and the next one.

**Dupont Alesta AM™** - a patented powder coating, treated with silver ion or silver zeolite technology that is known to inhibit the growth of microbes on powder coated steel.

# ProSolve Twinslot Uprights Fixing Details

## FIXING DETAILS FOR ALL TWIN SLOT UPRIGHTS

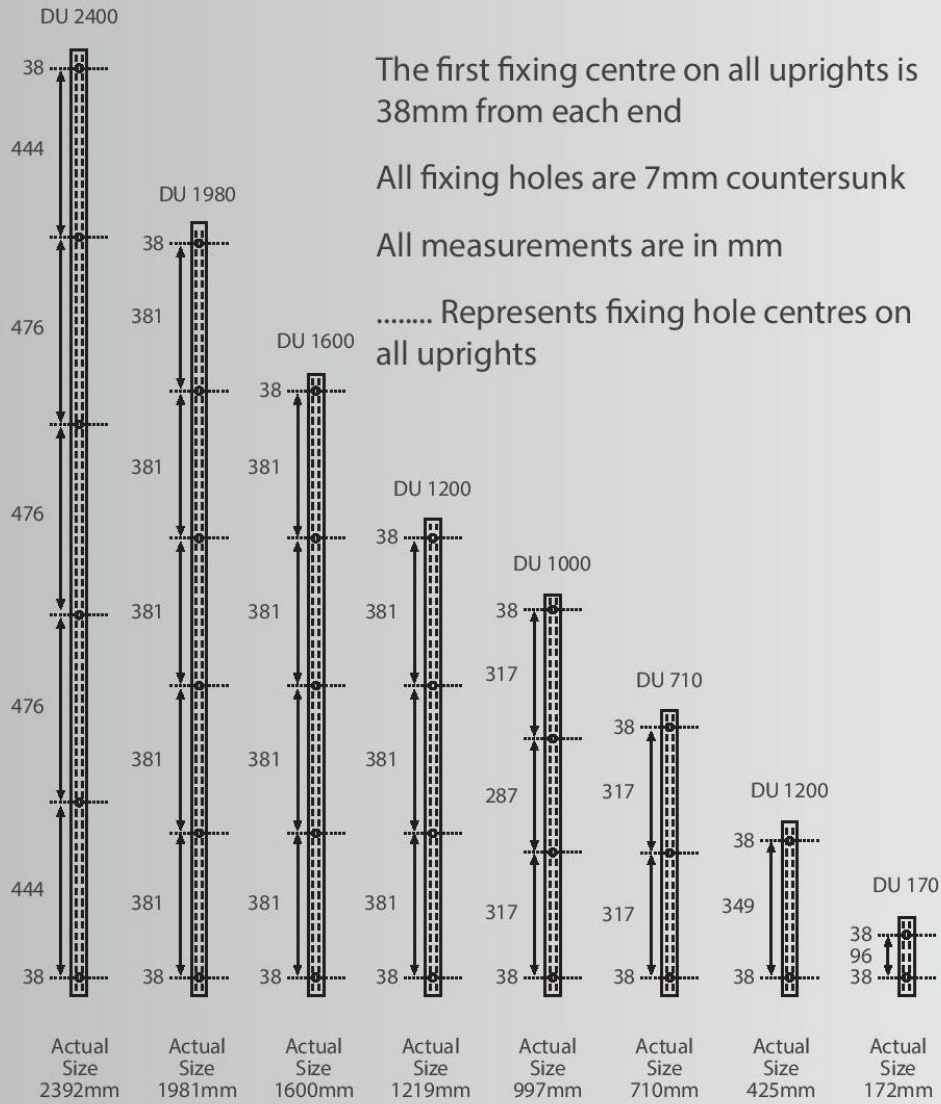

## ProSolve Twinslot Brackets Fixing Details

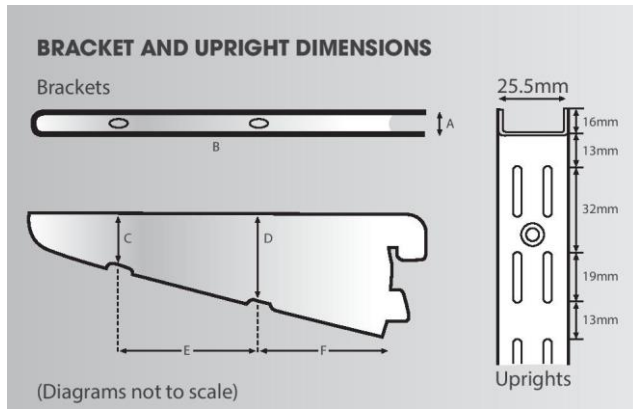

STANDARD BRACKETS	Code	A	B	C	D	E	F
Actual dimensions in mm	SBD120BC	12.5	110	18	39	60	32
	SBD170BC	12.5	165	18	39	97	46
	SBD220BC	12.5	215	18	39	131	61
	SBD270BC	12.5	268	18	39	167	76
	SBD320BC	12.5	317	18	39	203	92
	SBD370BC	12.5	366	18	39	227	117
	SBD420BC	12.5	420	18	39	330	280
	SBD470BC	12.5	470	18	39	160	298
	SBD570BC	12.5	570	18	39	168	372
	SBD610BC	12.5	608	18	39	218	378

MEDIUM DUTY BRACKETS	Code	A	B	C	D	E	F
Actual dimensions in mm	DMDB370BC	13.5	370	18	39	122	234

HEAVY DUTY BRACKETS	Code	A	B	C	D	E	F
Actual dimensions in mm	DHB370	13.5	370	18	39	122	234
	DHB470	13.5	470	18	39	160	298
	DHB610	13.5	610	18	39	218	378

## ProSolve Twinslot Upright Fixing Details

We recommend that 3" No.10 screws are used with the relevant wall plugs. We also recommend that individuals should consult a suitably qualified person to ensure that the uprights are installed correctly.

### Fixing Pack Code: UFP

Recommended centres for uprights is 500-600mm.

A shelf overhand of approximately 150mm should be left at each end. The type and thickness of shelf material and the application must be considered before fixing the system.

Before drilling, hammering or putting a screw into a wall, be sure you've checked what's behind it with a pipe, cable and stud detector (also known as a multi-purpose digital detector). They're simple to use and will let you

know if there are any pipes, cables or studs where you're planning to work. Simply run it over the surface of the area and it will tell you where hazards lie.

On masonry walls – walls made from bricks and mortar - you'll need a hammer-action drill with a masonry bit. You'll also need at least 50 mm screws and wall plugs to go through the plaster and into the wall behind.

For stud partition walls, the screws need to go directly into the timber noggins (horizontal) or studs (vertical part of the frame). You can find them by just tapping and listening, or by using an electric stud detector.

For heavy loads we'd recommend 38 mm or 50 mm screws as these have a strong fixing and don't need wall plugs. The screws should be the heaviest gauge that the holes in the bracket will take. This is usually a 4 mm gauge on small brackets and 5 mm or 5.5 mm on larger ones.

### ProSolve Twinslot Brackets – Recommended Weight Loadings

Code	Description	Recommended Weight Loadings
SBD120BC	120mm Twin Slot Shelf Bracket	151kg
SBD170BC	170mm Twin Slot Shelf Bracket	108kg
SBD220BC	220mm Twin Slot Shelf Bracket	84kg
SBD270BC	270mm Twin Slot Shelf Bracket	69kg
SBD320BC	320mm Twin Slot Shelf Bracket	60kg
SBD370BC	370mm Twin Slot Shelf Bracket	57kg
SBD420BC	420mm Twin Slot Shelf Bracket	68kg
SBD470BC	470mm Twin Slot Shelf Bracket	80kg
SBD570BC	570mm Twin Slot Shelf Bracket	77kg
SBD610BC	610mm Twin Slot Shelf Bracket	74kg

Code	Description	Recommended Weight Loadings
DMDB370BC	370mm Medium Duty Twin Slot Shelf Bracket	76kg

Code	Description	Recommended Weight Loadings
DHB370	370mm Heavy Duty Twin Slot Shelf Bracket	114kg
DHB470	470mm Heavy Duty Twin Slot Shelf Bracket	103kg
DHB610	610mm Heavy Duty Twin Slot Shelf Bracket	97kg

Note: To calculate the weight loading in Newtons, multiply the kg load by a factor of 9.81

### ProSolve Twinslot Brackets – Steel Grade

ProSolve Stainless Shelf Brackets and Upright Stainless Steel Grade 202

## **ProSolve Twinslot Brackets – Steel Thickness**

ProSolve Stainless Shelf Brackets and Uprights are fabricated from 1.5mm thick steel.

### **SHELVING CARE ADVICE**

The ProSolve Twinslot system already has an antibacterial coating which is specifically designed to ensure that bacteria cannot reside on the surface, the system should just need a wipe with a damp cloth when required. Do not use any strong detergents or abrasive cleaners.